

Prelab Assignment

Experiment 2

ECE 482

Fig. 1 shows the power stage of the drivetrain boost converter to be assembled in experiment 2. For all parts of this prelab, consider operation of the converter at an operating point around which:

- $V_{bat} = 26 \text{ V}$
- $V_{bus} = 50 \text{ V}$
- $P_{out} = V_{bus}I_{bus} = 250 \text{ W}$
- $\Delta i_l = 10\% \text{ of } I_L$
- $10 \text{ kHz} < f_s < 250 \text{ kHz}$

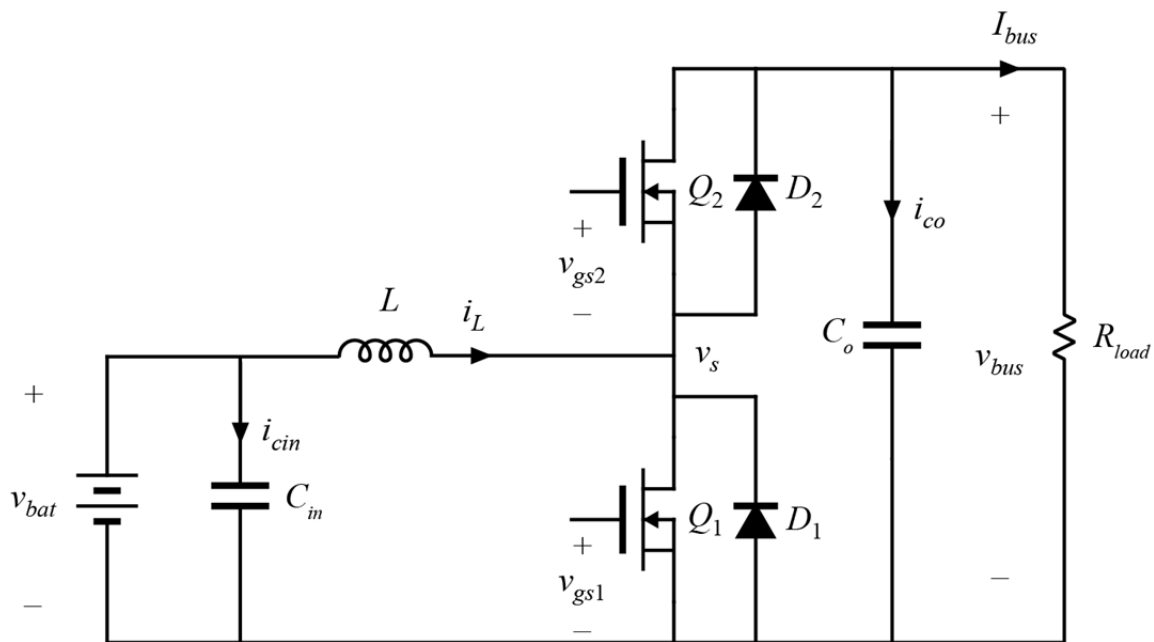

Figure 1: Open loop boost converter (implementation shown with MOSFET devices)

Note that the switching frequency is bounded, but not uniquely specified for this circuit. You are free to select your own switching frequency, which will factor into your decisions in Part 2 and Part 3 of this prelab.

Part 1: Boost Converter Steady-State Waveforms

Sketch the steady-state voltage and current waveforms for L , C_o , Q_1 , Q_2 , D_1 and D_2 , assuming that Q_1 and Q_2 are driven synchronously with a small, non-zero deadtime. For C_o and C_{in} , select capacitor(s) from the experiment 2 parts kit which give an appropriate capacitance at for each element, keeping in mind the RMS current ratings of the devices.

Part 2: Switching Device Implementation

In the experiment 2 parts kit, you have the option to select from two power MOSFETs, two IGBTs, and three Diodes (each labeled as quantity: X). Select which devices you will use to implement the boost converter, and explain why you chose the devices that you did. Some factors which you may want to consider include conduction and switching losses of the device in-circuit, voltage and current capabilities of the device, switching speed, availability of app notes and device models, etc. Note that switching losses scale with switching frequency, so your decisions for both are interrelated.

Specify: which devices are selected, and explain why this choice is better than alternatives.

Part 2: Boost Converter Inductor Design

The magnetics library available for use in this lab contains several ferrite core geometries and two different core materials. Datasheets describing the important parameters of core shapes, sizes, and materials are linked from the course website. Design the best inductor you can for the application described in the above paragraphs; you may want to consider maximum flux density, size, weight, copper loss, core loss, fringing effects, feasibility of physically winding the number of turns, etc. Note that smaller cores may require higher switching frequency, so your decisions for both are interrelated.

Specify: selected core, wire gauge, number of turns, and air gap length, and explain what factors were considered and how they motivated your selection.

Additional Notes:

You will have the opportunity to confer with your lab partner and change your design before beginning Experiment 2, and again following experiment 3. The purpose of this prelab is to work through the design tradeoffs once, not necessarily to obtain an optimal result the first time. You are free to choose what of the proposed considerations you wish to take into account when selecting semiconductor devices, magnetics design, and switching frequency; as long as you explain why the choices you made are better than the alternatives.